

LOD

Installation

Instructions



POLARIS RANGER
2013+

BULL BAR
DESTROYER SERIES

Installation

Bull Bar

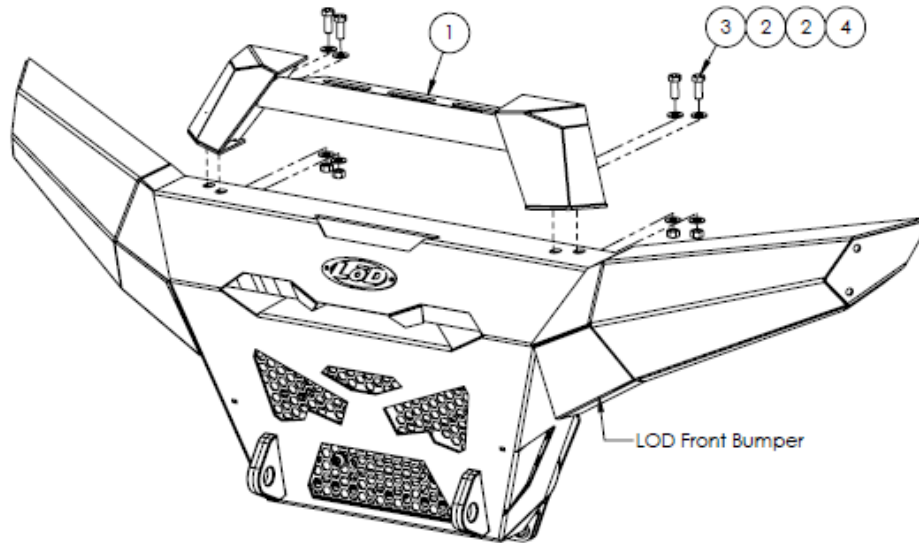

ITEM	QTY	PART NUMBER	DESCRIPTION	ITEM	QTY	PART NUMBER	DESCRIPTION
1	1	4PBB1300-01	Bull Bar	3	4	HB381616ZPGR5	Hex Nut 3/8-16 x 1.00"
2	8	FW3813YZ	Flat Washer 3/8" x .812, YZ	4	4	HN3816ZPGR5	Hex Nut 3/8-16, ZP

1. Remove the bolts from the top flange of the bumper as shown in Figure 2.
2. With the bolts removed, locate the Bull Bar and the 3/8" hardware.
3. Attach the Bull Bar as shown above and attach using the 3/8" hardware. It's best to loosen the lower bolts on the stiffener bracket to help ease installation. See Figure 1.
4. Center the Bull Bar and then tighten the bolts to the Bull Bar and Stiffener Brackets.

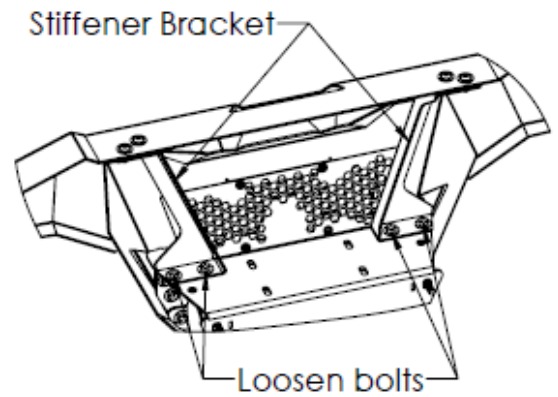

Figure 1. Loosen Stiffener Brackets

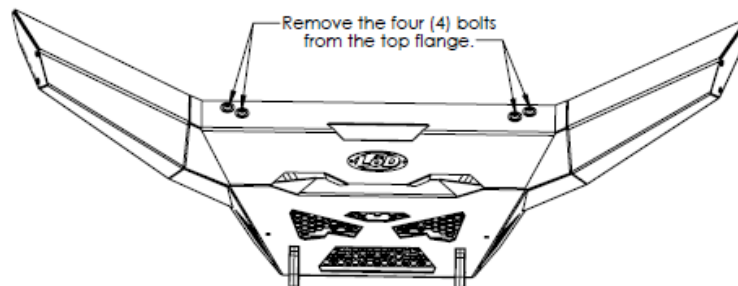

Figure 2. Remove Bolts from Top Flange of Bumper

****Maintenance****

- Periodically check and re-tighten all fasteners.
-
- Periodically check your product for scratches, dings, or rust spots which can happen over time or after heavy use. It is important to address these areas as soon as possible to prevent rust and corrosion from spreading. We recommend using Rustoleum® brand Black Semi-Gloss Protective Enamel (oil based). Apply using a foam brush by dabbing to match the powder coat texture.





**Polaris Ranger
DESTROYER SERIES**

**BULL BAR
SHIPPING SHEET - BOX 1**

Packaged by:

On:

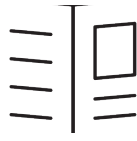

INSTRUCTION
SHEET

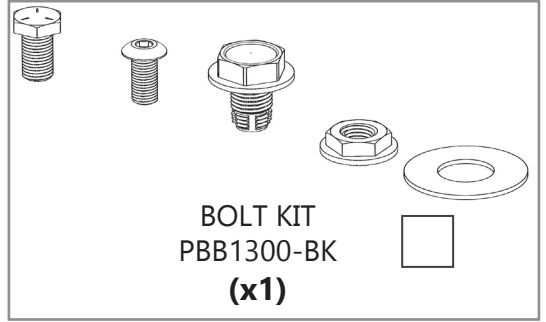

BOLT KIT
PBB1300-BK
(x1)

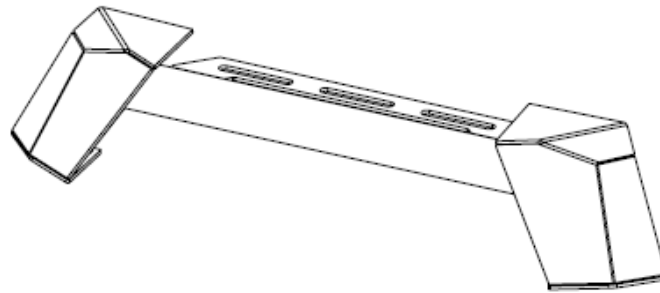

BULL BAR
4PBB1300-01
(x1)





**Polaris Ranger
DESTROYER SERIES**

BULL BAR
BOLT KIT

Packaged by:

On:

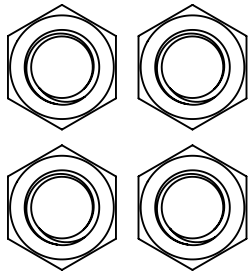

HEX NUT 3/8-16

(36306)

(x4)

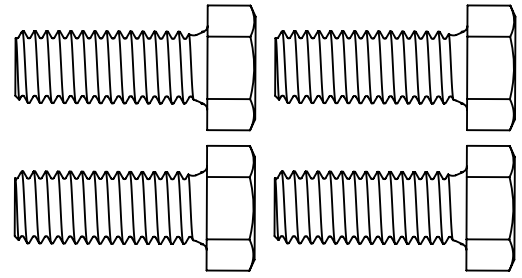

HEX BOLT 3/8-16 X 1.00"

(11105742)

(x4)

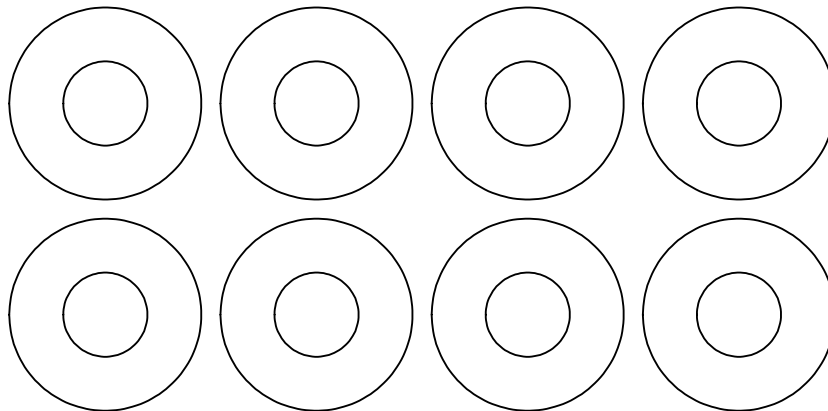

FLAT WASHER

Ø3/8" X .812"

(98023A031)

(x8)

